

# Kriegers Flak - Combined Grid Solution KF CGS

Experiences from project execution and preparing for operation

*Elke Kwapis, 50Hertz Transmission*

*Vladislav Akhmatov, Energinet*

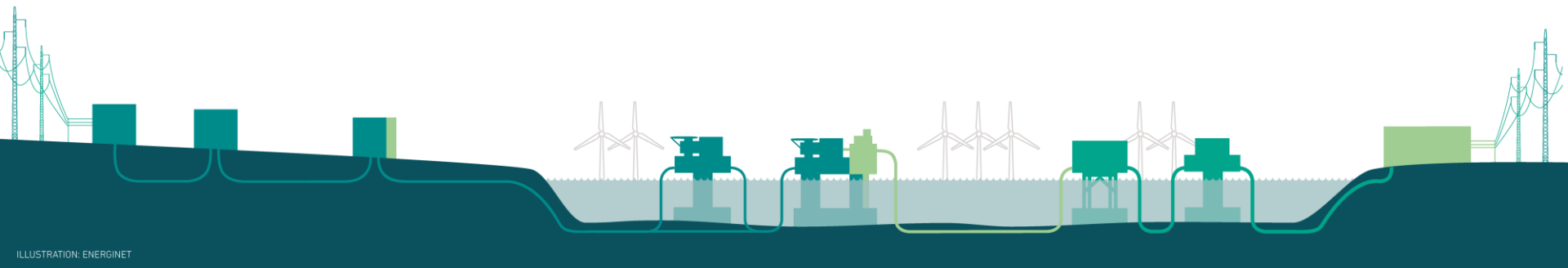

## Agenda

1. Intro: Trailer Kriegers Flak – Combined Grid Solution
2. Project Overview: Kriegers Flak – Combined Grid Solution
3. Challenges, opportunities & lessons learned
4. Electrical power transmission and control principles

## 1. Intro: Trailer Kriegers Flak – Combined Grid Solution



# Kriegers Flak - Combined Grid Solution

## 2. Project Overview: Kriegers Flak – Combined Grid Solution

*Elke Kwapis*

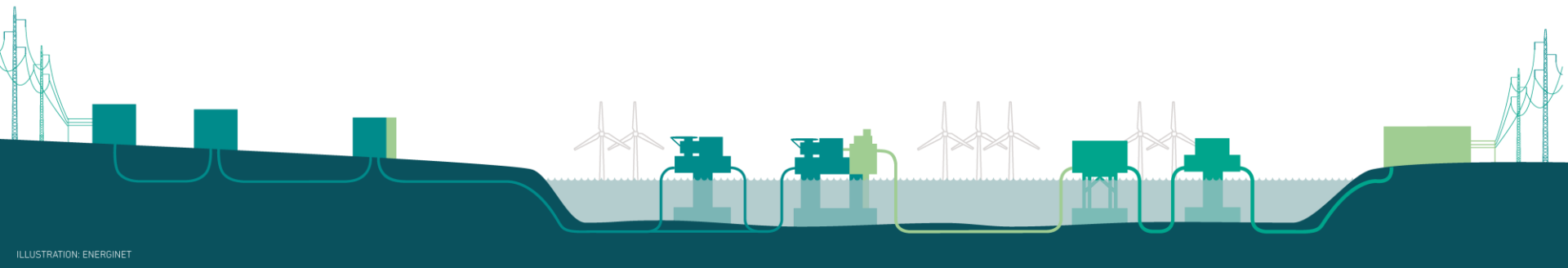

## 2. Project Overview Kriegers Flak – Combined Grid Solution KF CGS

**A common project of German TSO 50Hertz and Danish TSO Energinet, co-financed by the European Energy Program for Recovery (EU)**

The Kriegers Flak - Combined Grid Solution is the world's first hybrid interconnector/OWP system.

It combines:

- the radial grid connections of the German OWP's Baltic 1 & 2 and the future Danish OWP Kriegers Flak with
- a cross-border interconnector between Denmark and Germany, connecting the German north-eastern region with the Danish area of Sjaelland

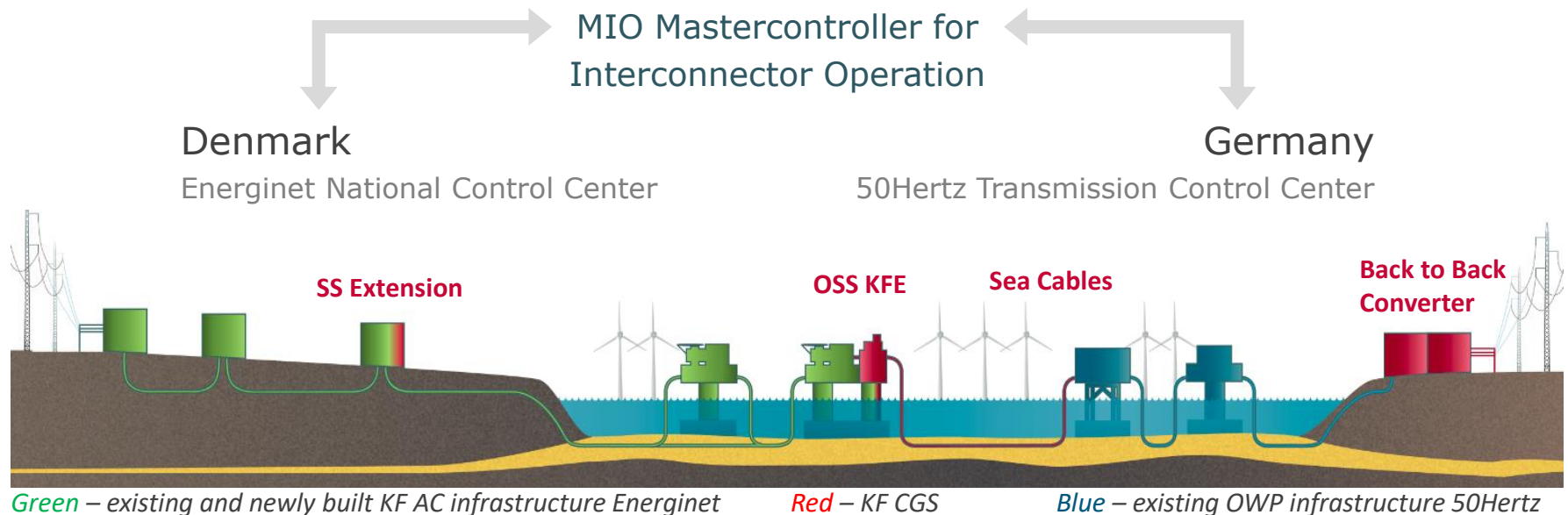

## 2.1 KF CGS Offshore Parts – OSS extension module KFE and Sea Cables

- EPCI for two AC sea cables connecting OSS Ba2 with OSS KFE
- EPCI for the HVAC offshore platform „KFE“ as extension of Kriegers Flak OSS KFB

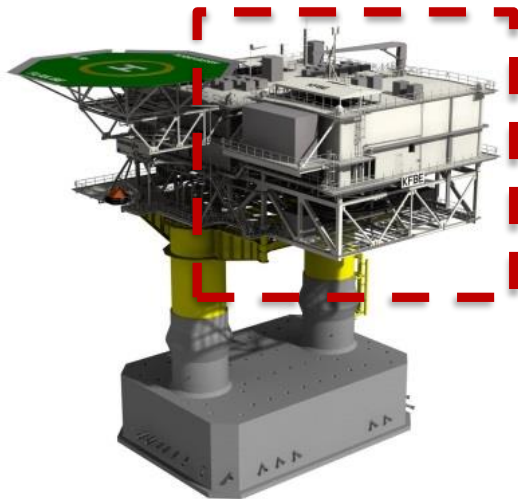

Offshore platform **KFB** (installed in 2018) connects the Kriegers Flak wind park to the Danish onshore grid.

The **KFB** platform is combined with the extension module **KFE** on one gravity base foundation.

Main components on **KFE**: transformer (connecting point of the German with the Danish side) and switchgear.

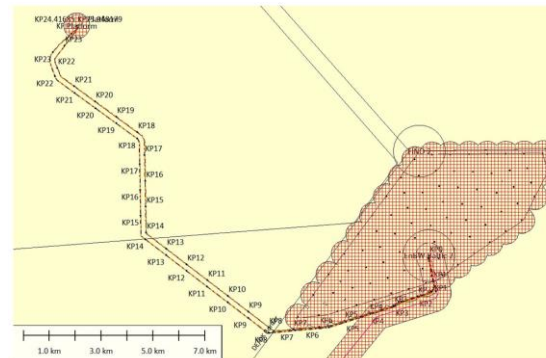

KF CGS sea cables route



One of the two KF CGS **AC sea cables** (150kV) during installation campaign in front of KFB platform.



**Baltic 2 Platform:** Existing and already operating. Connecting the Baltic 2 wind park to the German onshore grid.

## 2.2 The Back to Back Converter in Bentwisch (GER)



Transformer and shunt reactor hall

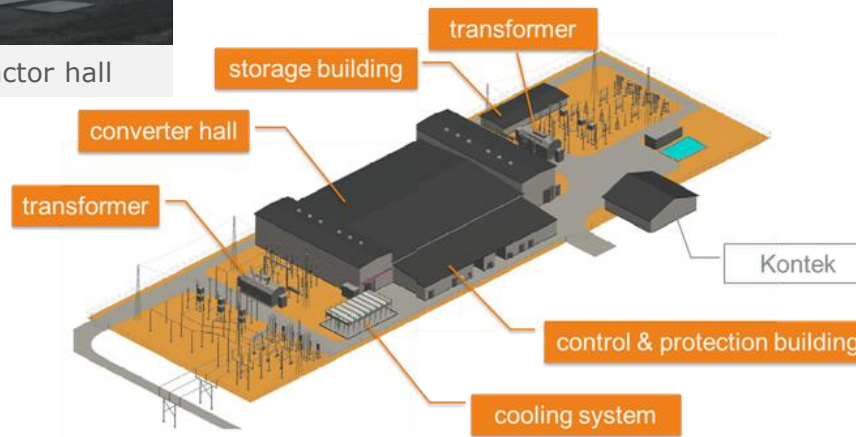

Valves assembled in valve hall

The Danish and the German transmission grids operate in a slightly different phase, which makes a transformation AC – DC – AC necessary.

In Bentwisch (close to the German coast of the Baltic Sea) a so called back-to-back converter (BtB) is built. It consists of two voltage source converters (VSC).

The converter will change the AC of the Nordic synchronous area into DC and directly back to AC, now adapted to the European synchronous area.



## 2.3 The MIO (Master Controller for Interconnector Operation)

KF CGS is the first interconnector between two countries (and bidding zones) that integrates infeed from two different national wind farms.

A new kind of calculation and control system is developed to control available capacities and flows of such a complex system.

### Tasks of the MIO:

#### 1. Calculating capacity for the market

(Taking designated topology, equipment ratings and wind forecasts into consideration)

- In case of wind forecast errors: corrections are needed
- First priority: Wind

#### 2. Avoid overload of equipment

#### 3. Keep voltage limits for BtB and wind farms

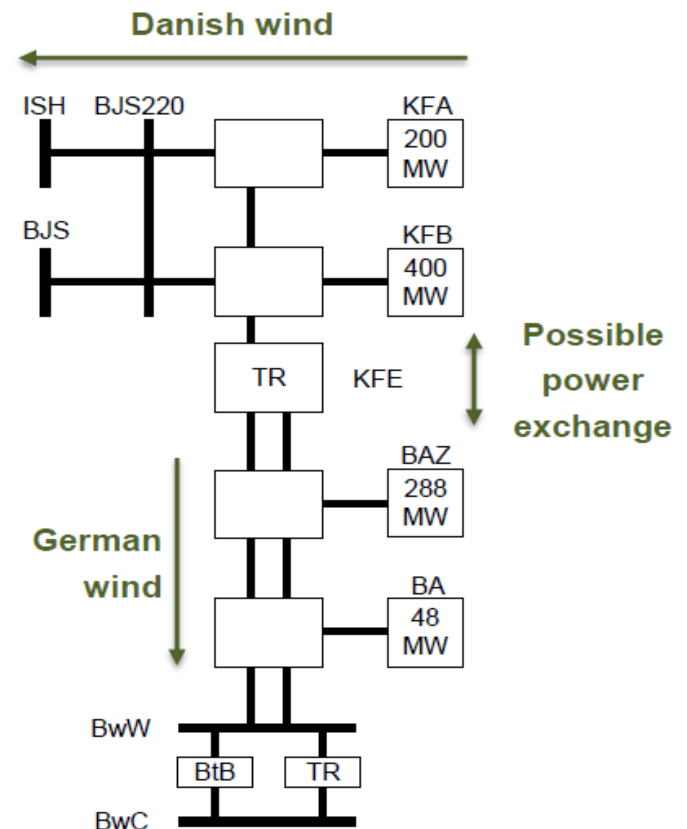



# Kriegers Flak - Combined Grid Solution

## 3. Challenges, opportunities & lessons learned

*Elke Kwapis*

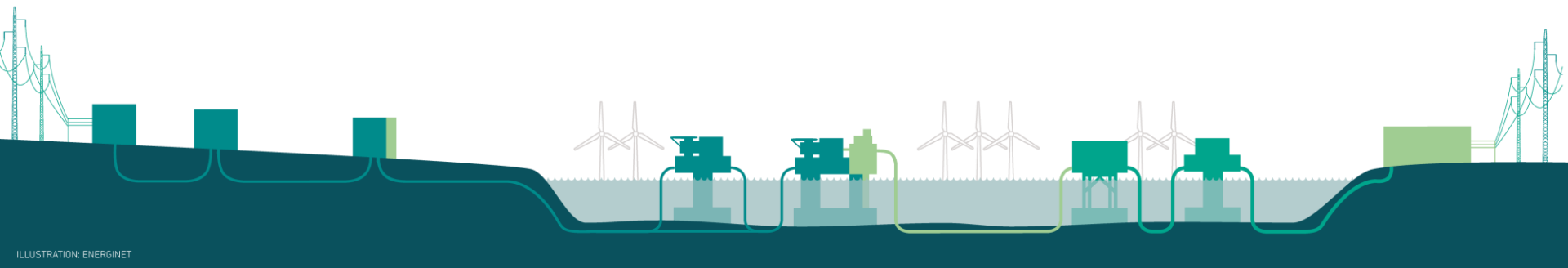

ILLUSTRATION: ENERGINET

### 3.1 Challenges (and Opportunities)



### 3.1 Typical challenges coming from the execution of complex infrastructure projects

Nothing new - no words needed...

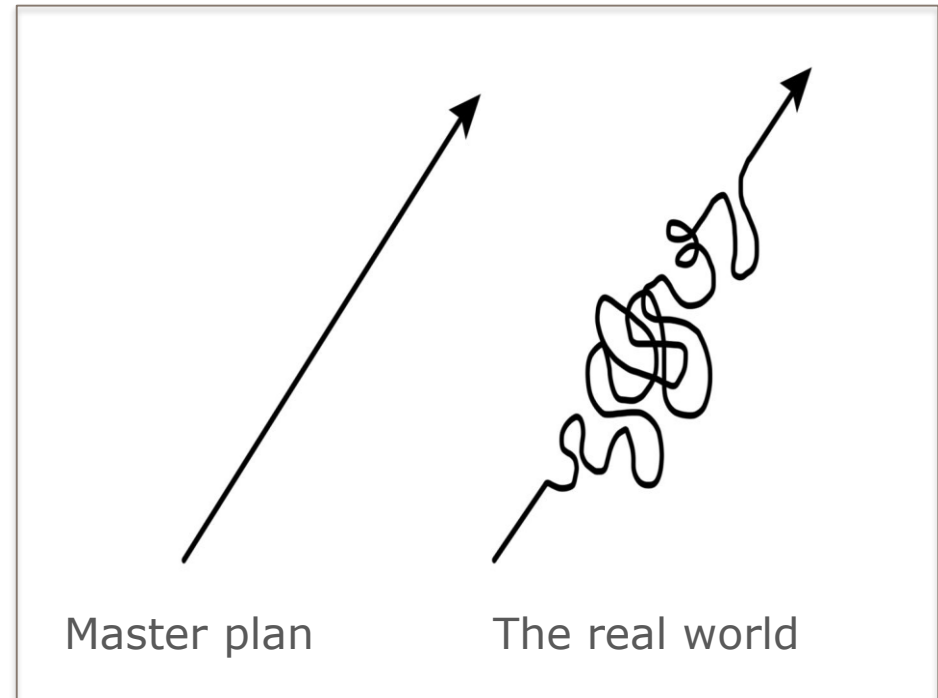

## 3.2 Challenges related to having two national TSOs as equal partners

### Need for new ways due to ownership of assets – 50% ownership for each TSO

- Contract setup for main contracts as 3-side contracts with both TSOs as employers
- Regular costs reimbursement for all project execution costs - will proceed in operation phase
- Different insurance approaches of the TSOs had to be aligned.
- System operation and maintenance strategies need to be harmonized.

### Mirrored project team – each key function in the project has its counterpart

- High amount of communication traffic
- Energinet in lead for Offshore / 50Hertz in lead for Back-to-Back

**Cultural clash – both TSOs are different**  
and so are the people

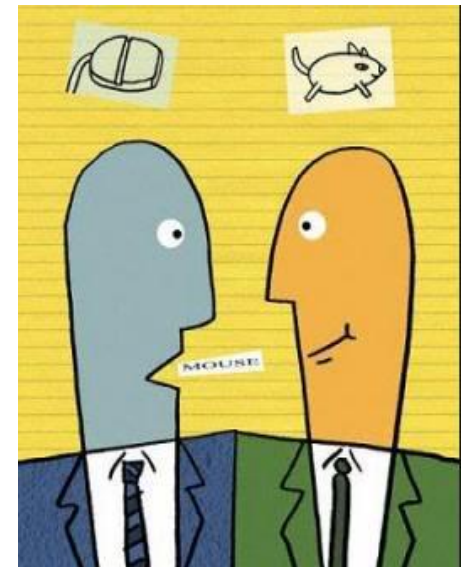

### 3.2 Opportunities related to having two national TSOs as equal partners

#### Best chance on experience exchange between two TSOs at a life project

the goal is the same –

the way to reach it can be very different

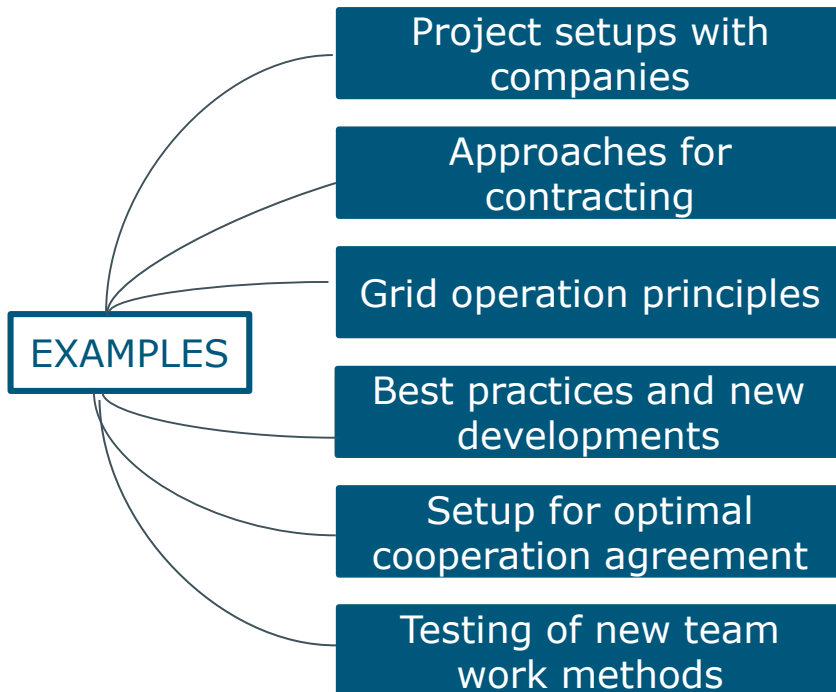

**ROC Drill concept** for Commissioning Workshop – result: smart ideas and good team spirit

### 3.3 Challenges & opportunities related to specific pilot characteristic

#### Main challenge: OWP infeed vs trading capacity

- There are different legal and market mechanisms on national and EU level for OWP infeed and for interconnectors
- or even no regulations covering the special case of a hybrid system like KF CGS

– Hybrid systems like the KF CGS are usually not covered by existing and future **market mechanisms** for interconnectors and the **legal national frameworks** for offshore wind.

– Therefore, a pilot project like KF CGS has to face certain **undefined situations** and questions. For example:

What shall be the definition (calculation) for the capacity available to the market when you have fluctuating wind infeed?

– **Intense communication** is needed with national regulators and on EU level to adapt existing and future regulations to the needs of hybrid systems.

### 3.3 Challenges & opportunities related to specific pilot characteristic

**Challenge: the interconnector infrastructure needs to be integrated into existing and new OWP infeed infrastructure and onshore substations**

- Sea cables had to be pulled in and terminated on **an operating Baltic2 platform** and with very **narrow space**
- Commissioning and the trial run for the overall KF CGS are planned to have as **little impact as possible on the windfarms**
- Discussions about **compensations for wind farms** are necessary
- Proper planning necessary to **avoid impacts on existing assets at onshore stations**

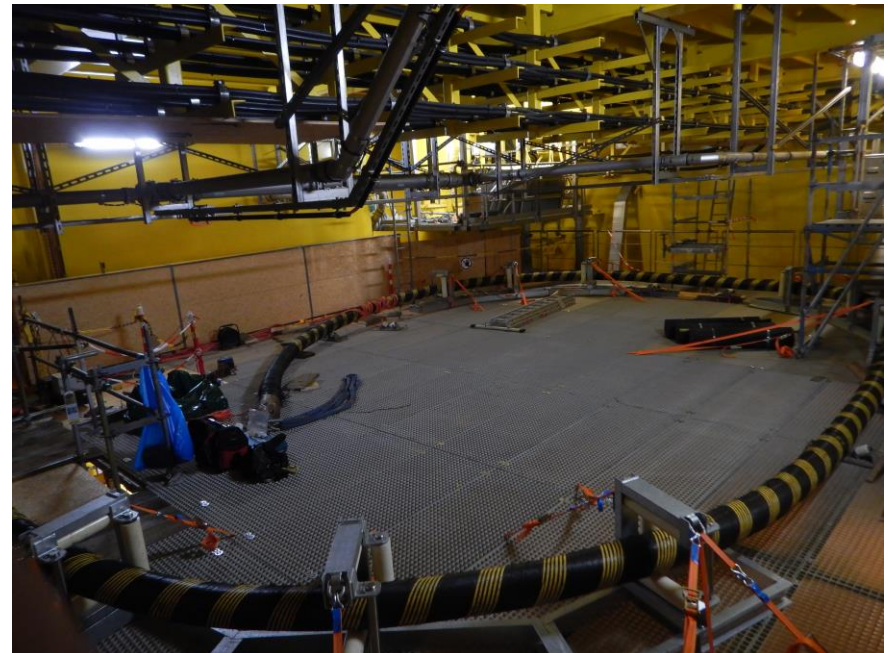

Sea cable pull in at Ba2 platform



## 3.4 Lessons learned

The two main focus areas are:

### I. External Stakeholders

Can be: national regulators, politicians, EU, public, approval authorities, wind farm owners, neighbour TSOs, market players, ...

→ Careful stakeholder analysis and monitoring throughout the overall project – keeping in mind the unique character of the project. The more stakeholders are involved, the bigger the effort to manage (secure the right and sufficient resources!)

### II. Internal Stakeholders

Can be: project sponsor, both project teams, any other related TSO department,...

***Never underestimate the human factor!***

More interfaces and more unexpected challenges lead to higher need for communication between the TSOs – to get the right support at the time needed



Team Day picture 2018

# Kriegers Flak - Combined Grid Solution

## 4. Electrical Power Transmission and Control Principles

*Vladislav Akhmatov*

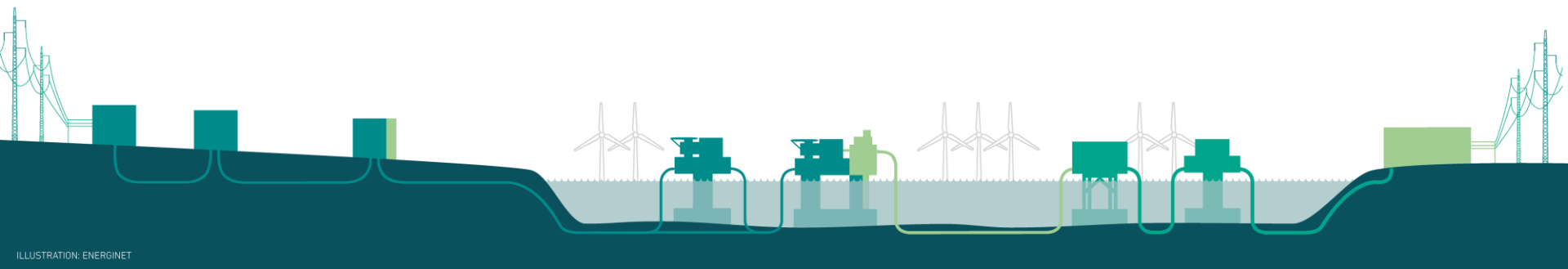
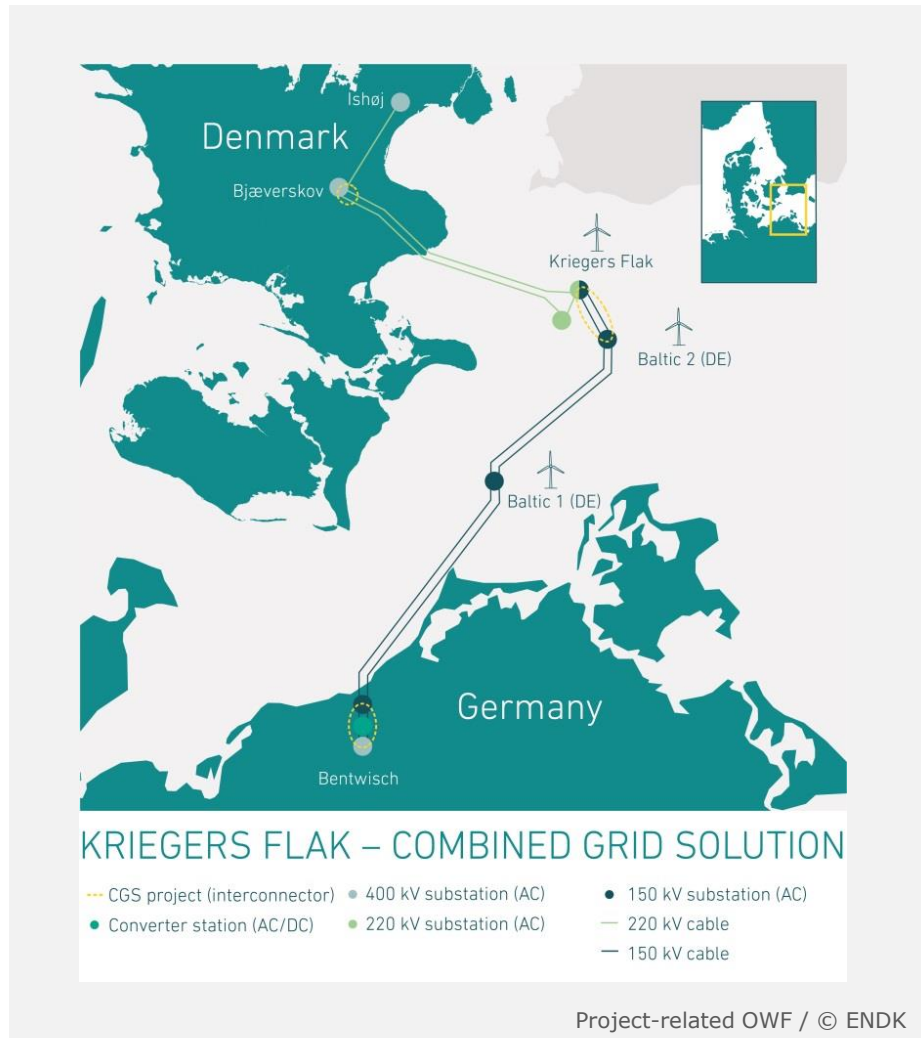

ILLUSTRATION: ENERGINET

## Kriegers Flak CGS - Outline



1. Outline of the Kriegers Flak CGS.
2. Already existing infrastructure for connecting of the offshore wind power plants (600 MW Danish and 336 MW German).
3. Added infrastructure for establishment of the interconnector.
4. HVDC VSC Back-to-Back (BtB) in Bentwisch (Germany) because of connecting two large asynchronous areas (400 MW).
5. The offshore infrastructure is HVAC cables and platforms with locations of wind power plants.

## Kriegers Flak CGS – Electrical System Assets

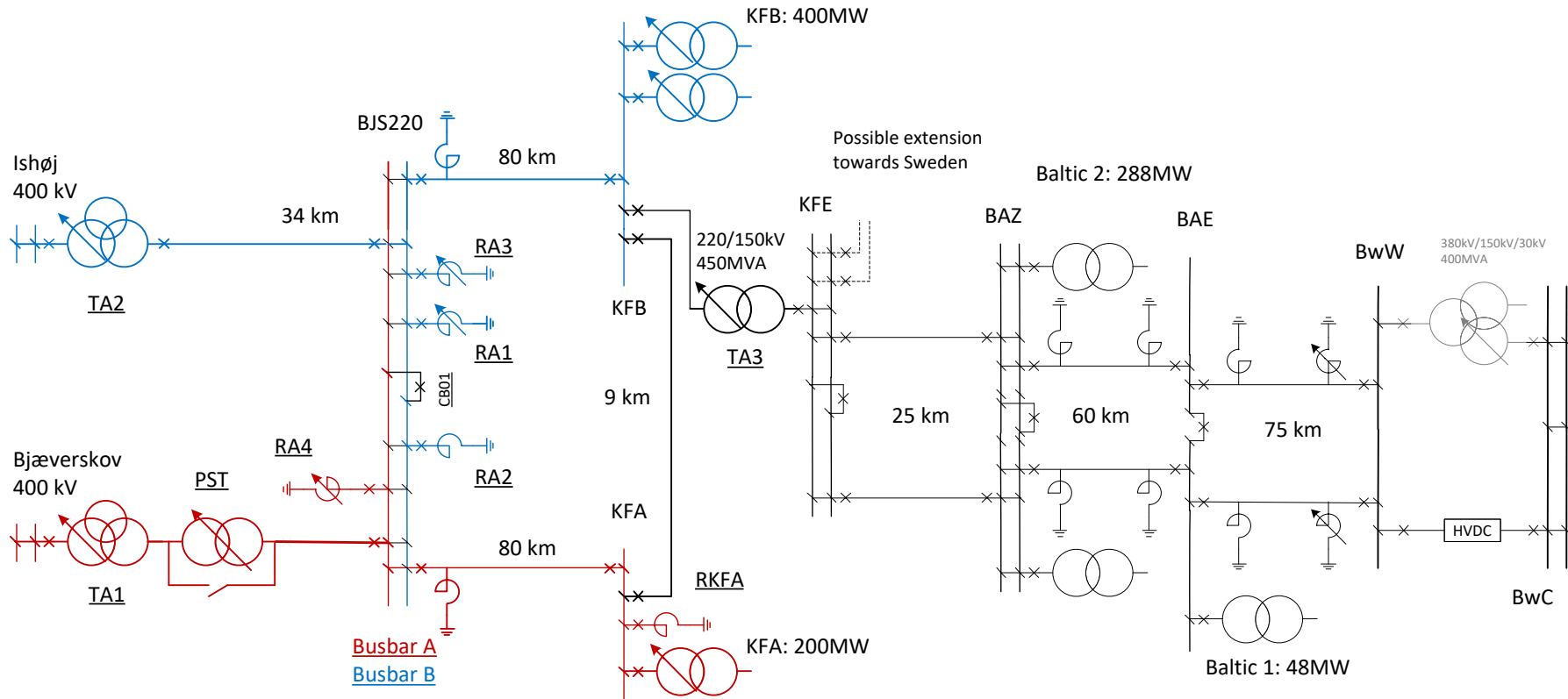

## Kriegers Flak CGS – Electrical System Assets

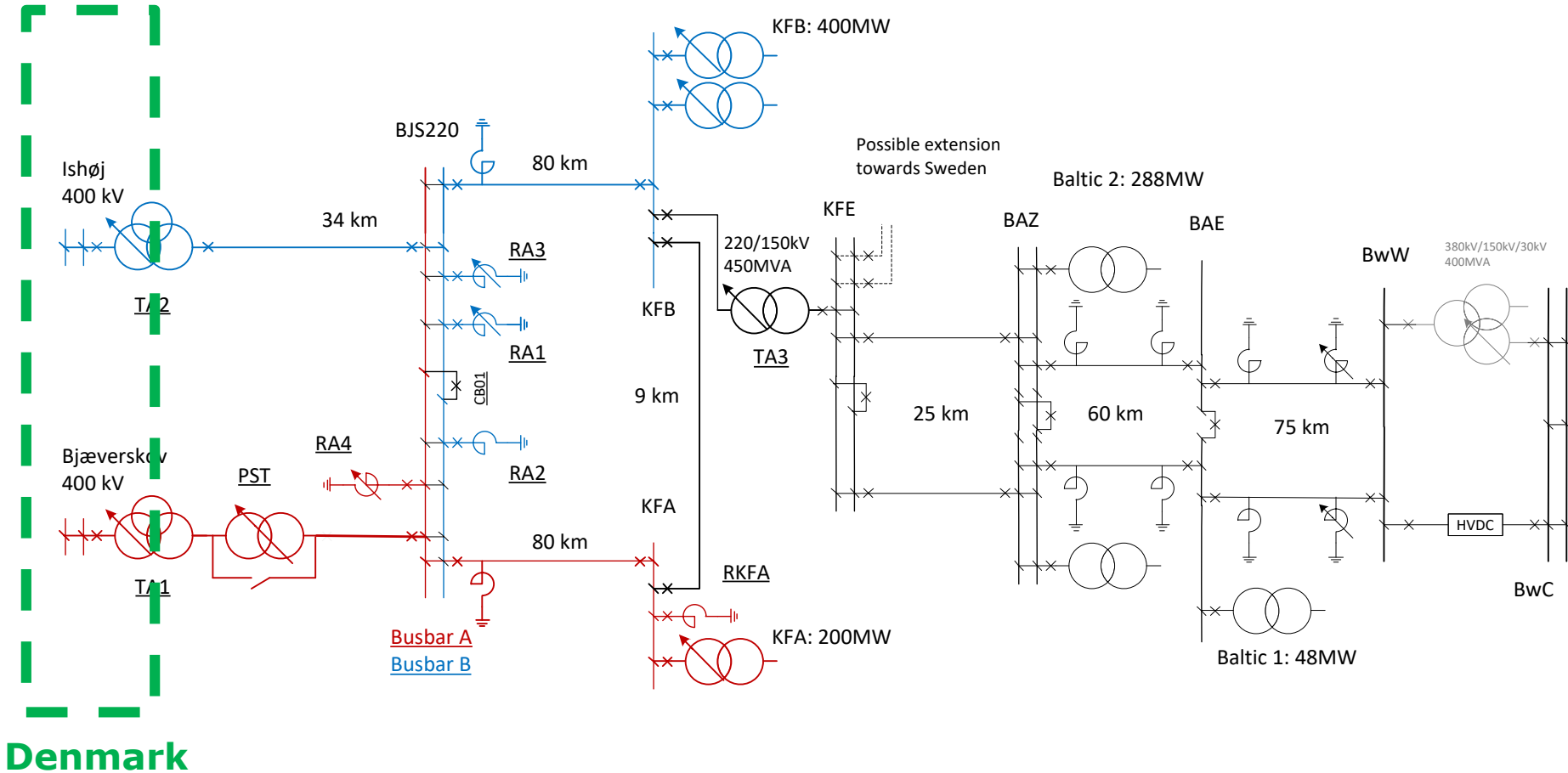

## Kriegers Flak CGS – Electrical System Assets

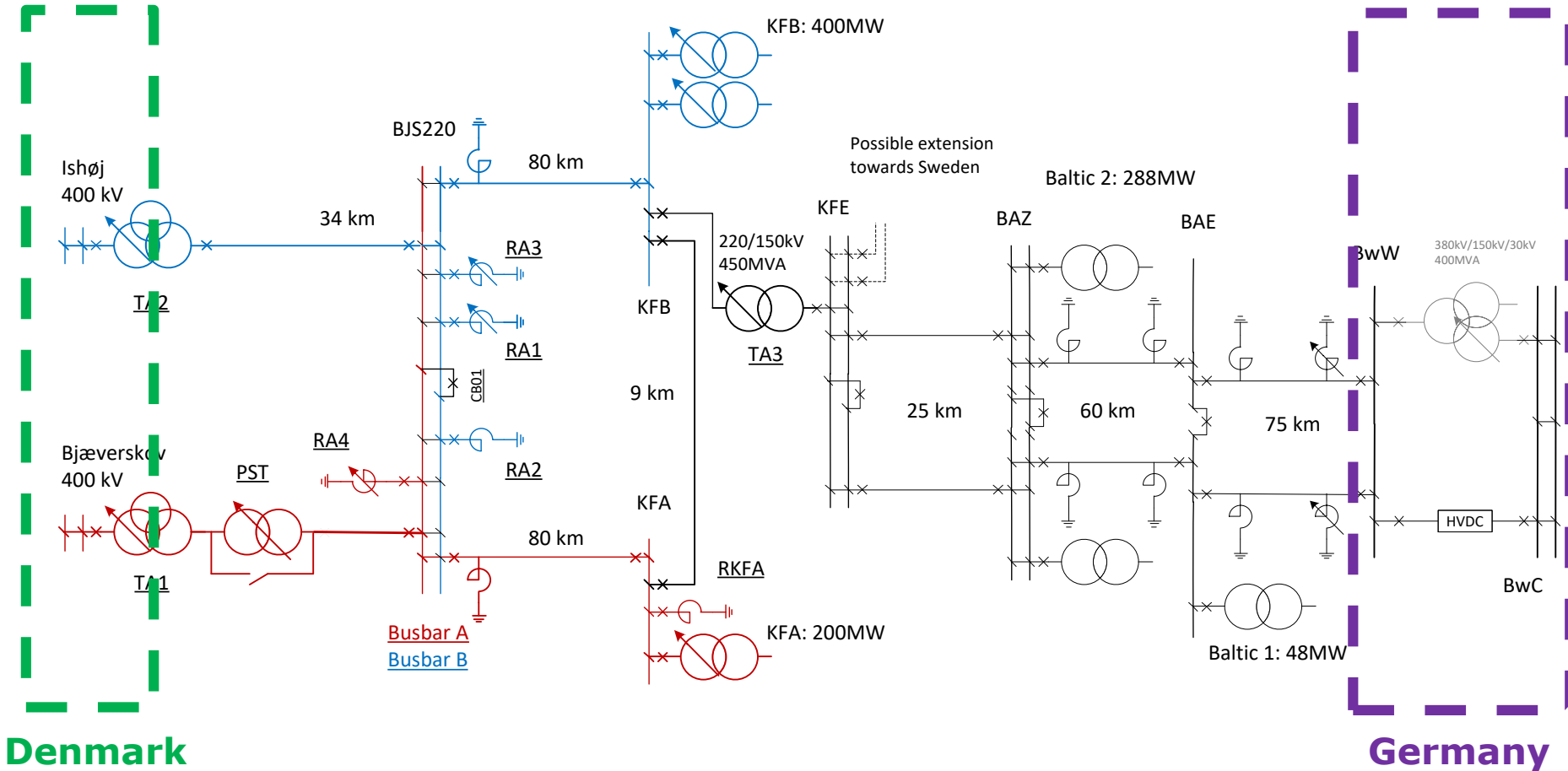

## Kriegers Flak CGS – Electrical System Assets

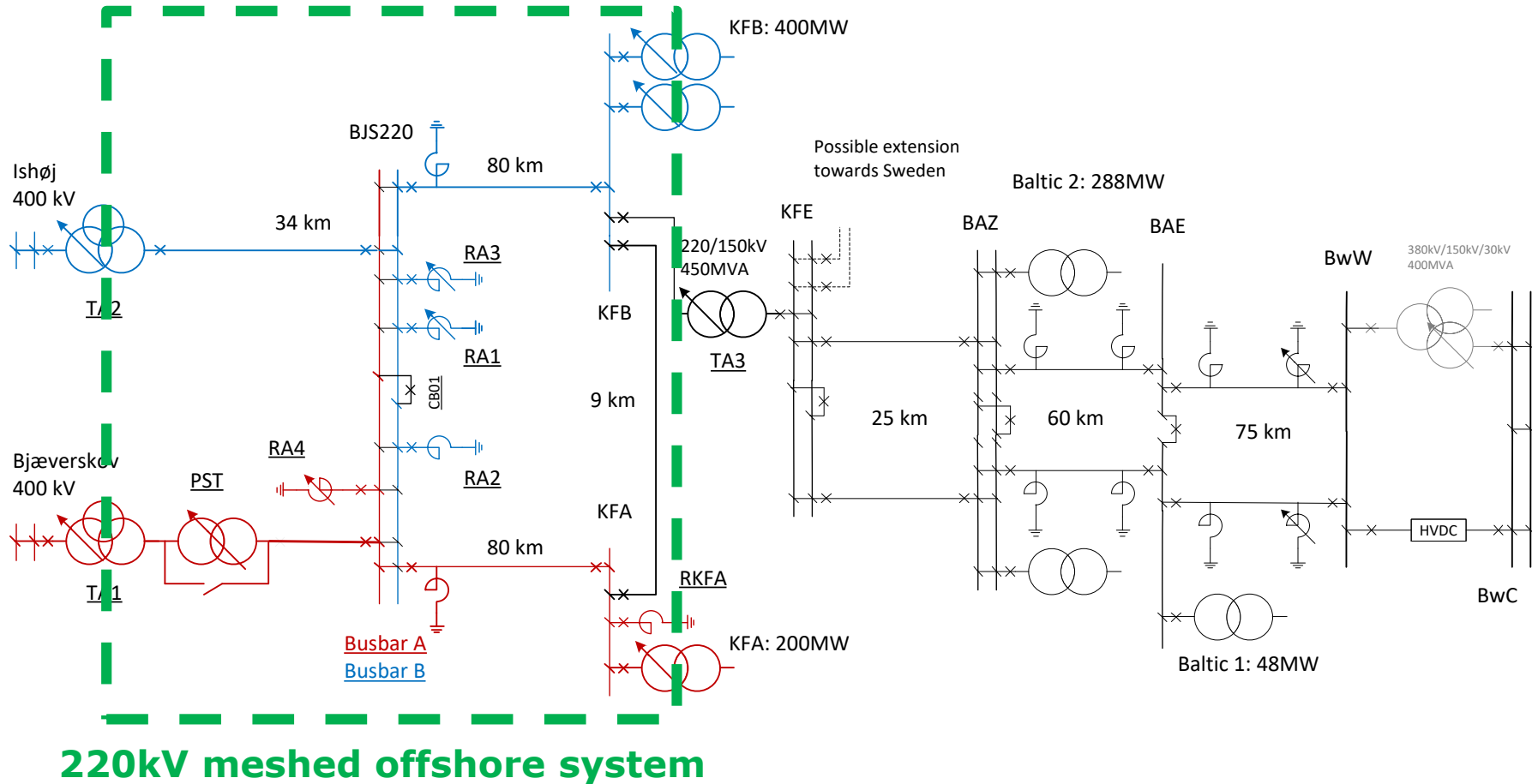



## Kriegers Flak CGS – Electrical System Assets

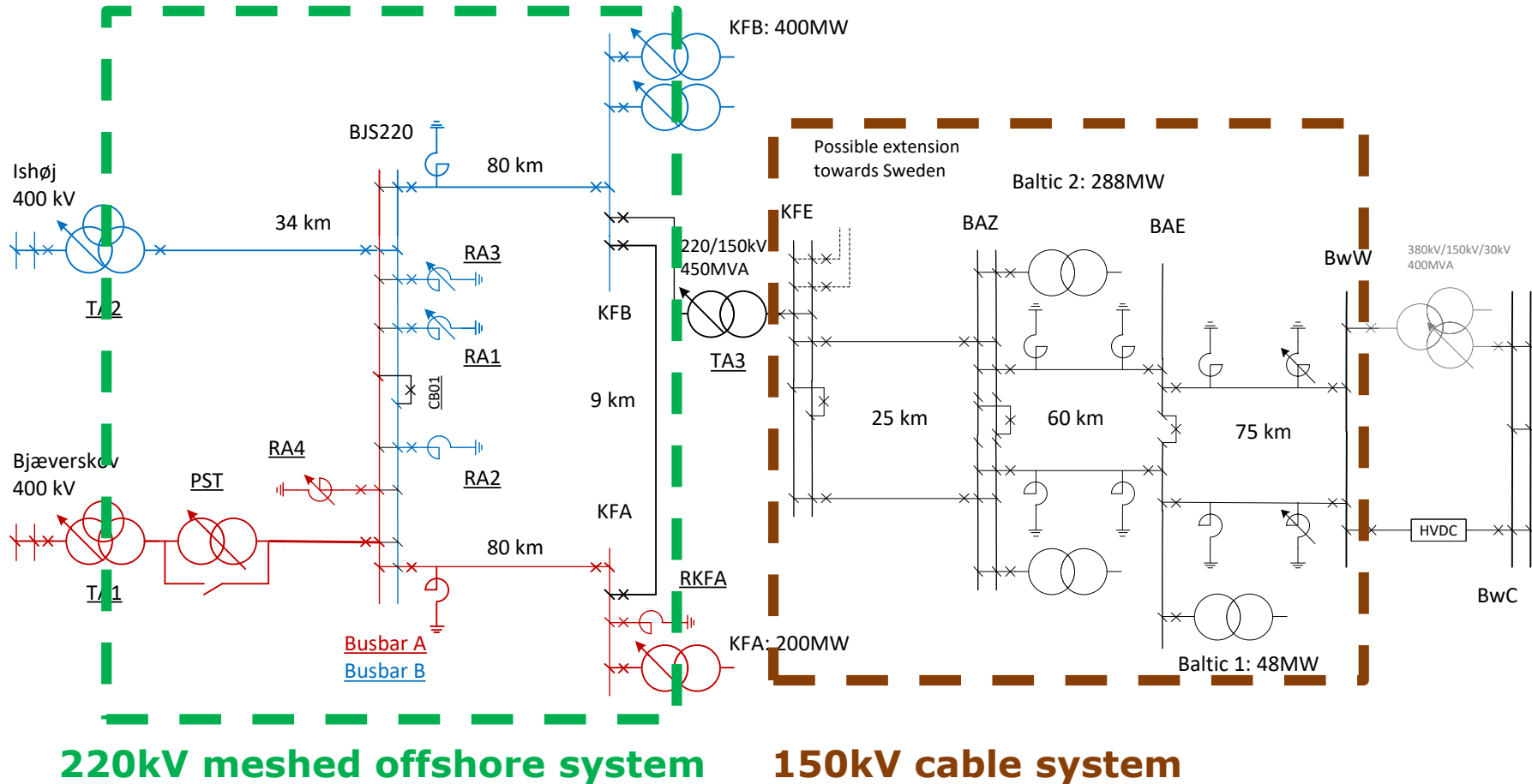

## Kriegers Flak CGS – Electrical System Assets

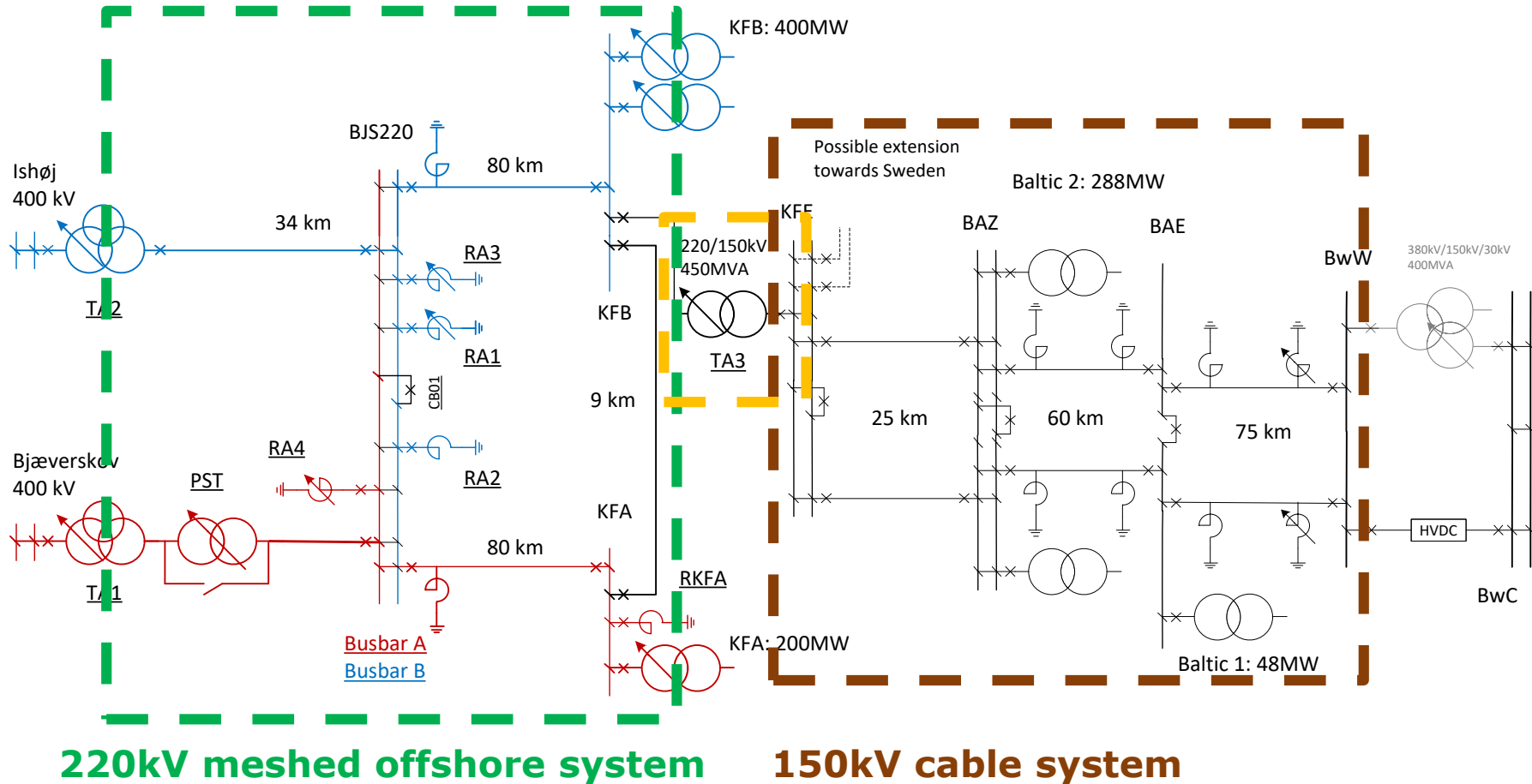

## Kriegers Flak CGS – Electrical System Assets

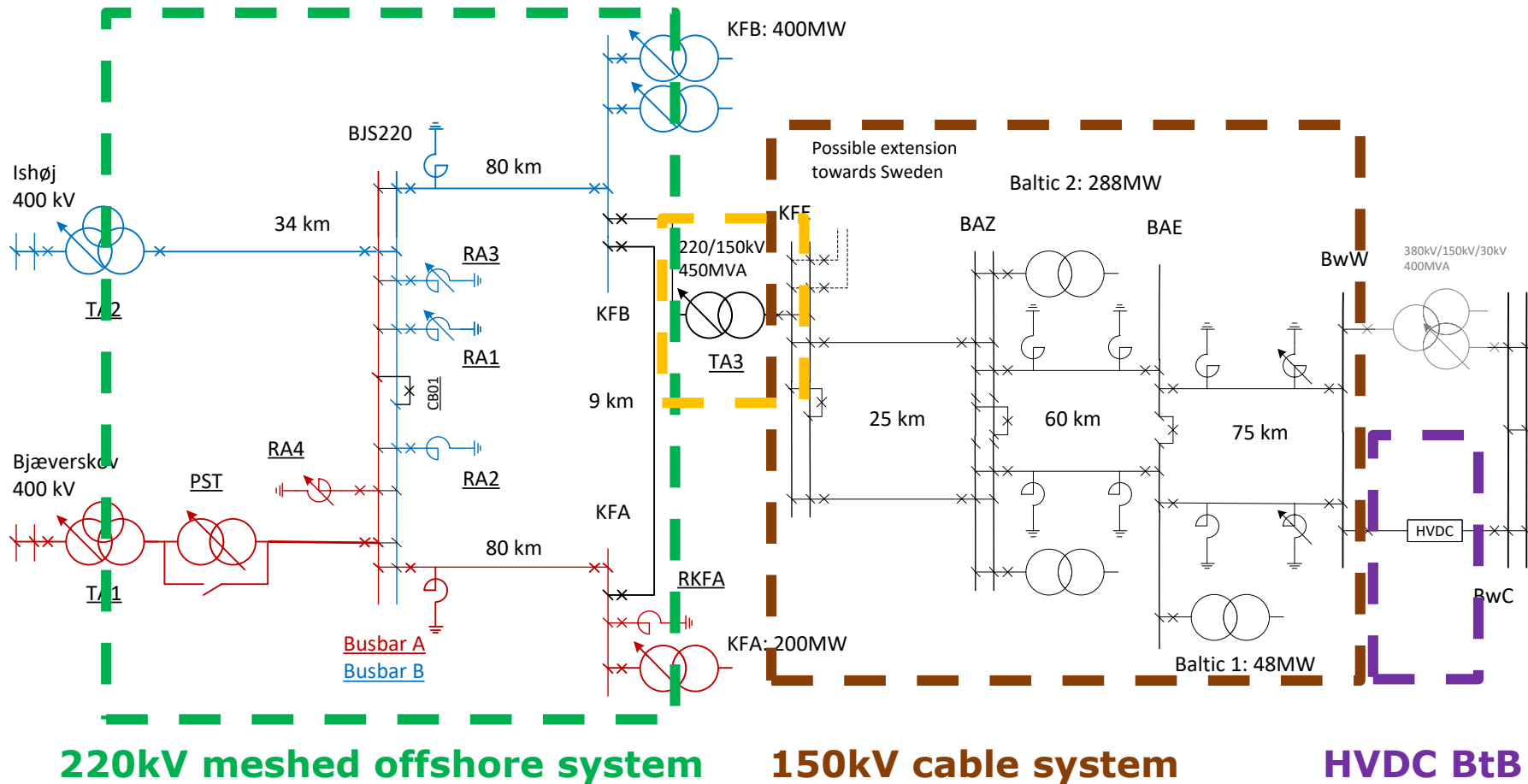

## How to operate Kriegers Flak CGS?

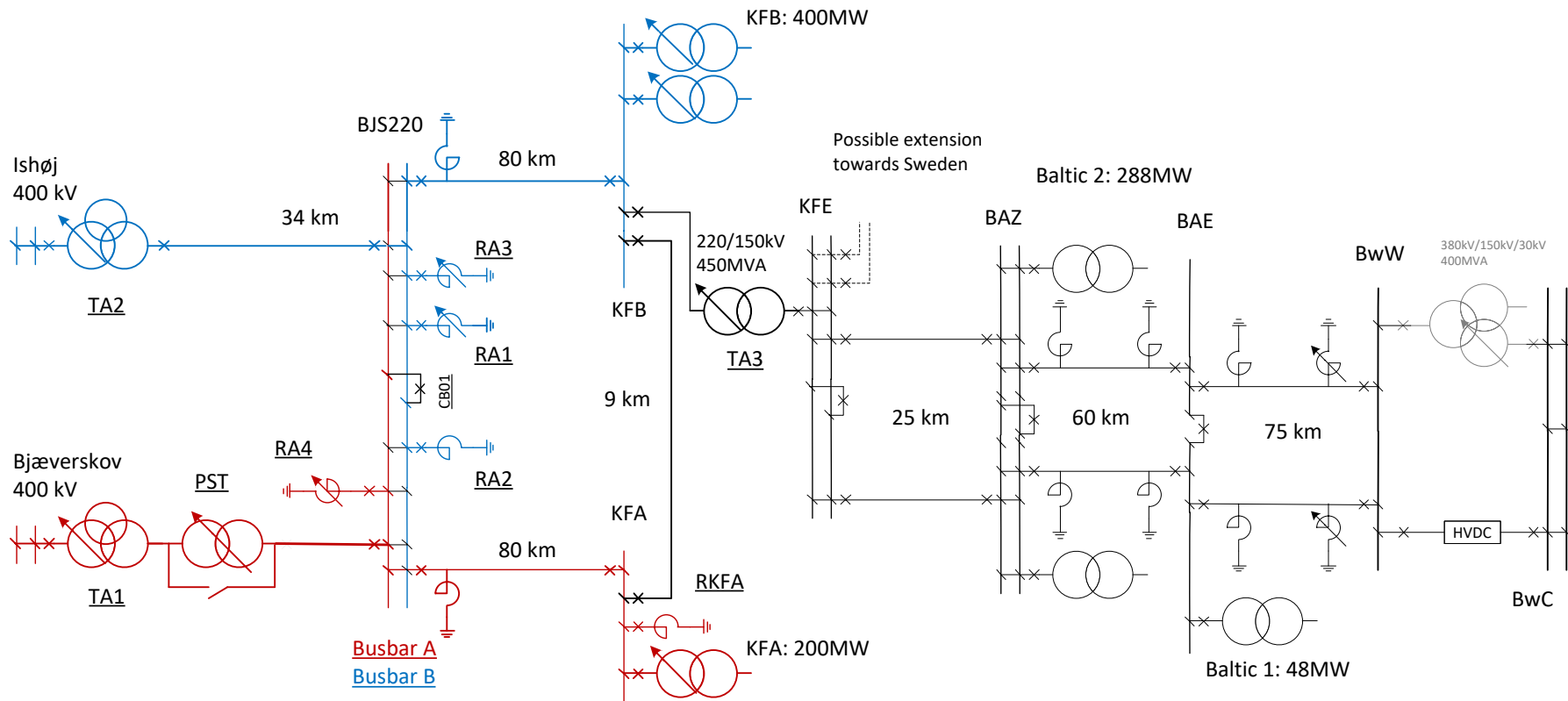

## How to operate Kriegers Flak CGS Matter of control

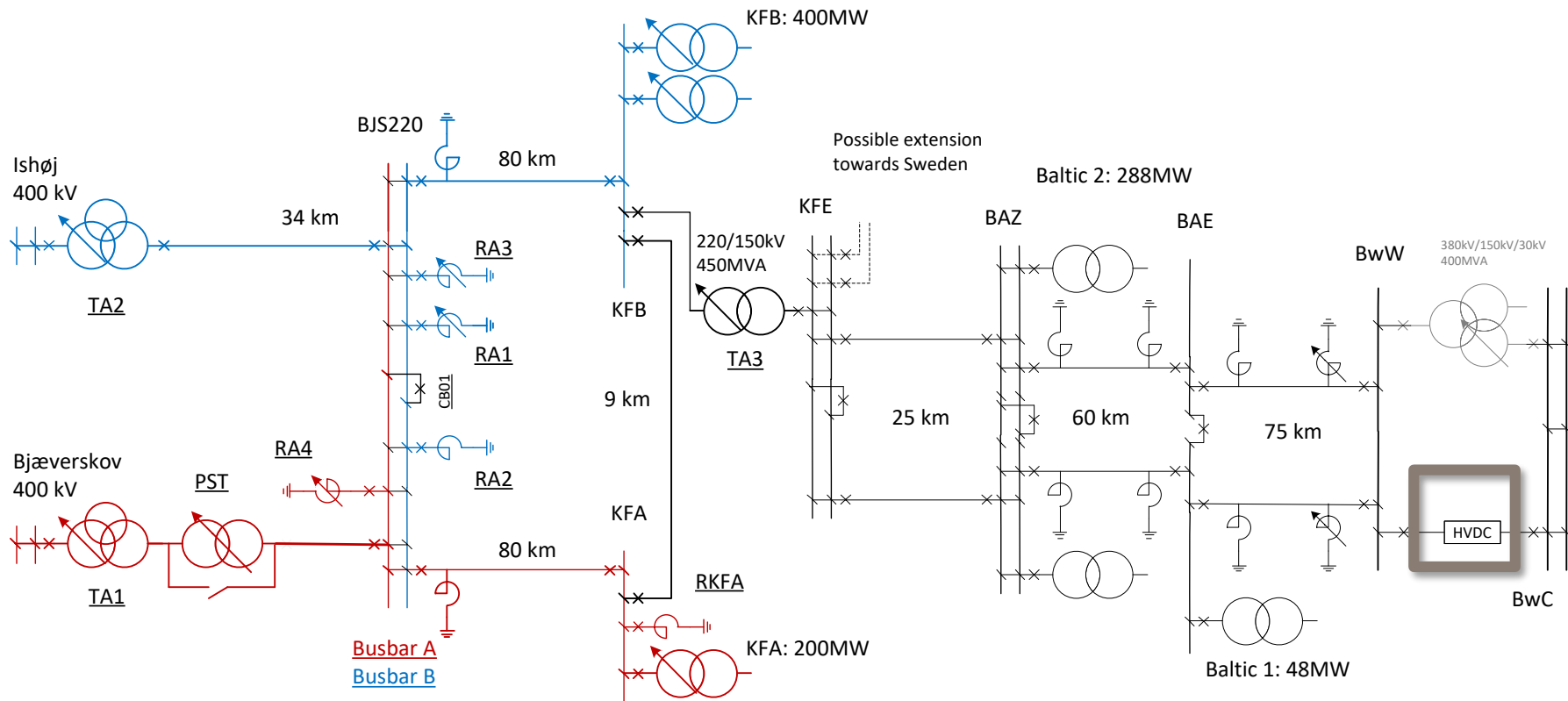

## How to operate Kriegers Flak CGS Matter of control

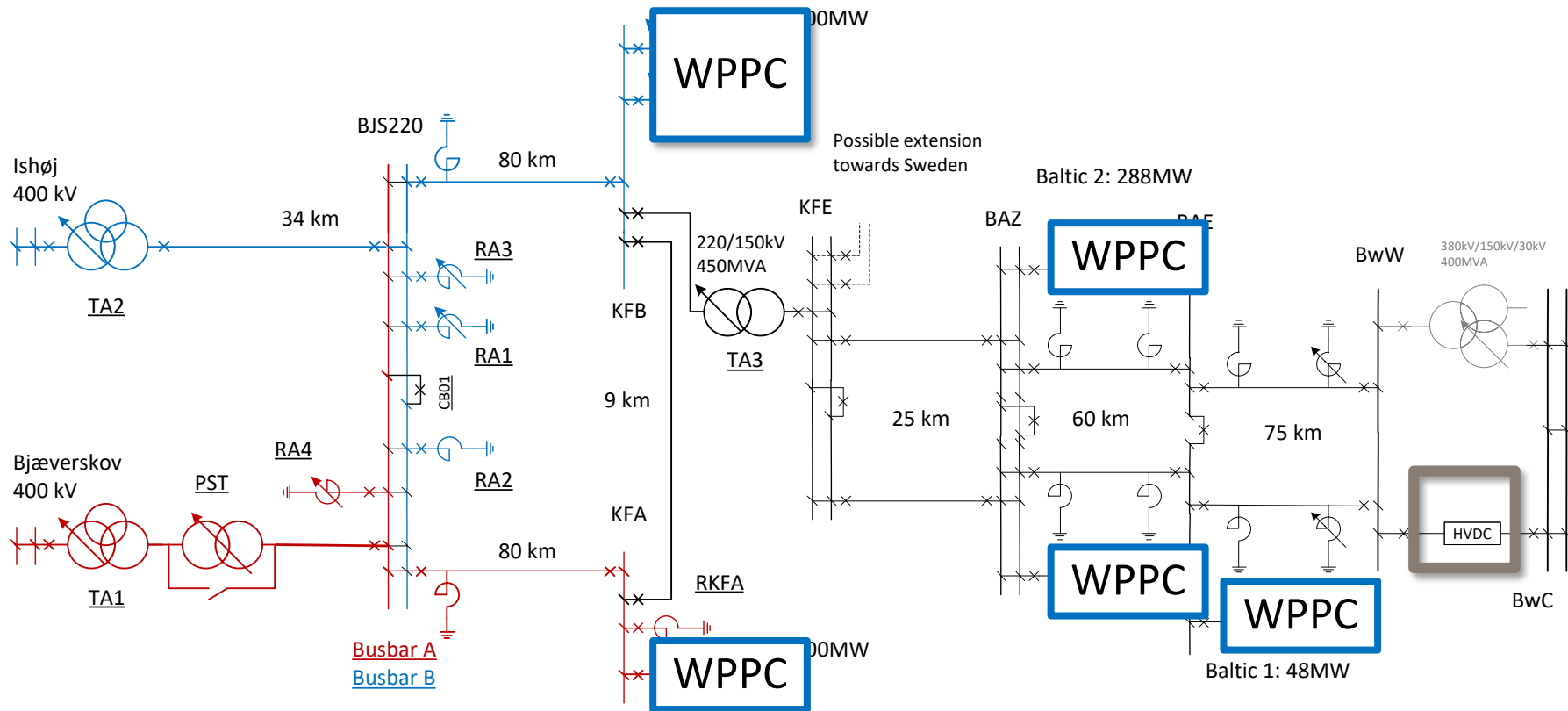

## How to operate Kriegers Flak CGS Matter of control

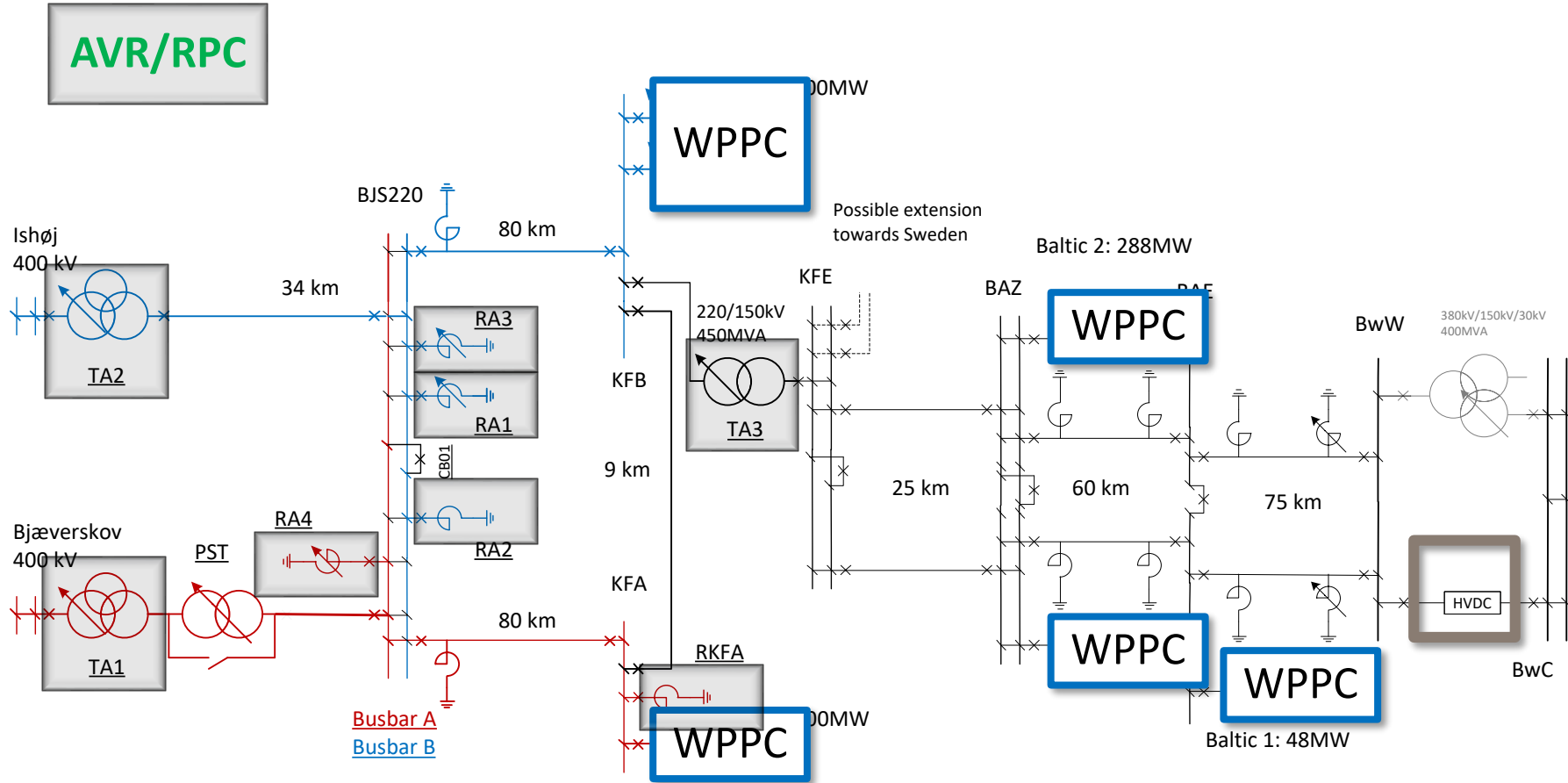



## How to operate Kriegers Flak CGS Matter of control

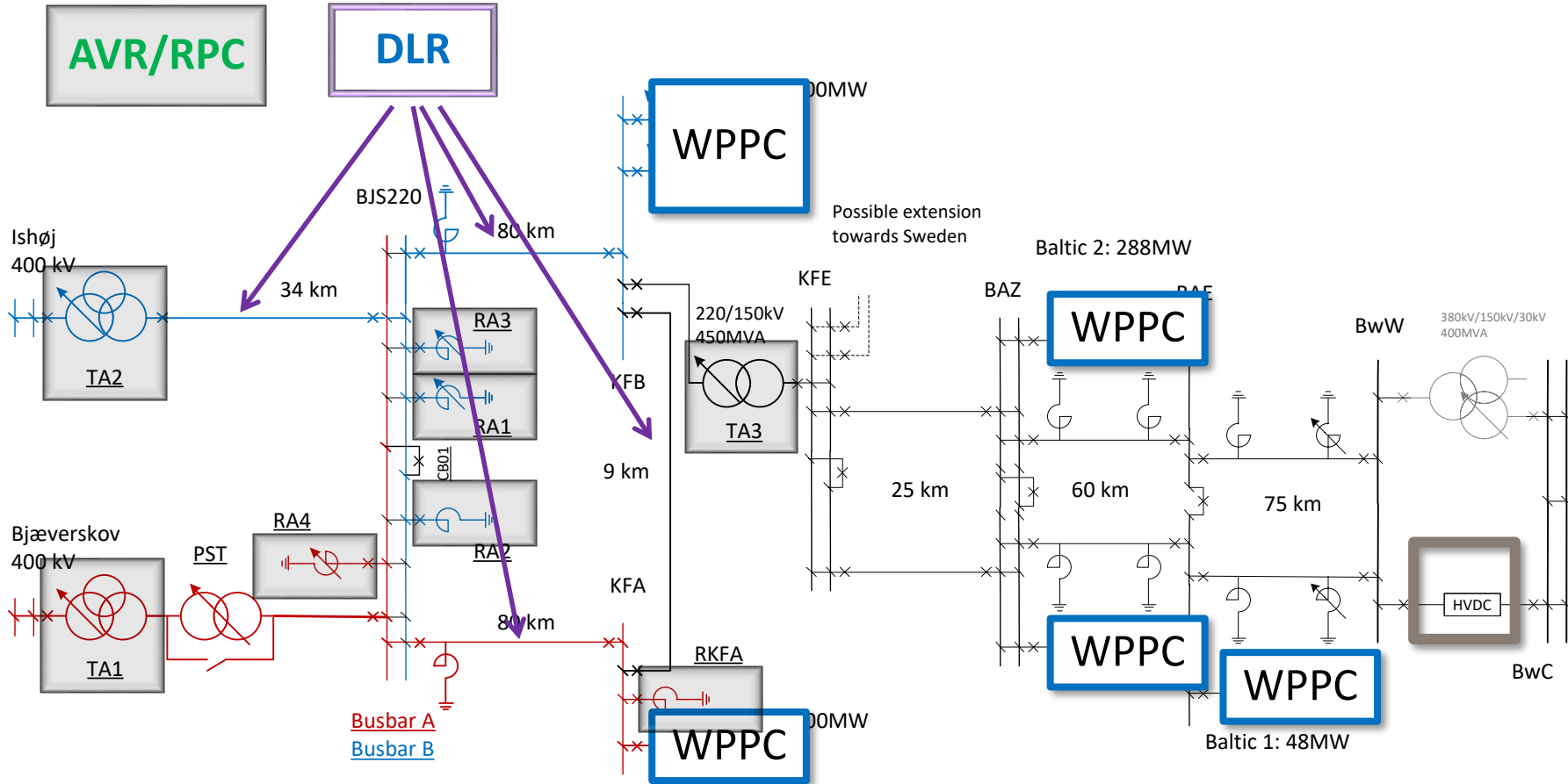

## How to operate Kriegers Flak CGS Matter of control coordination

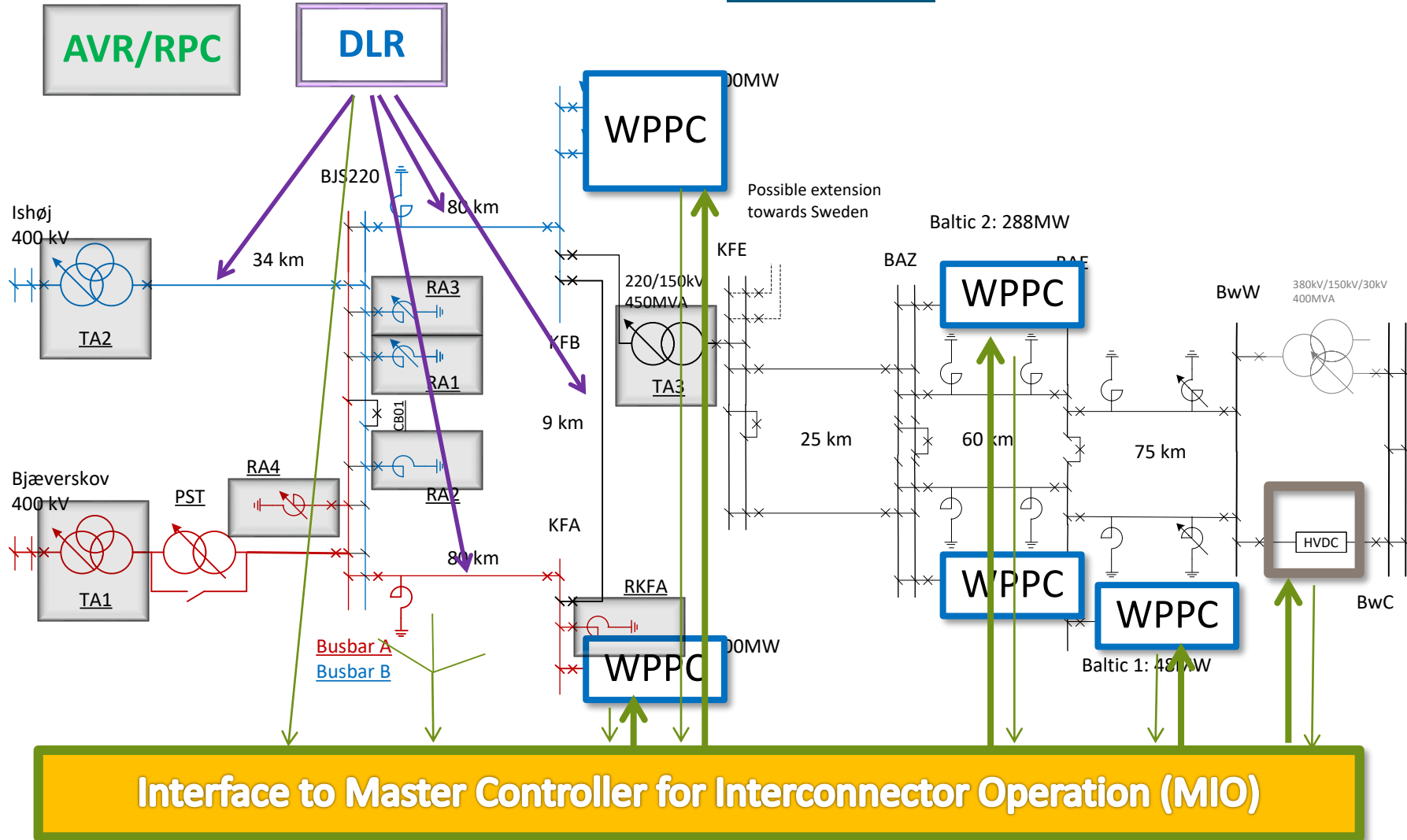

## Kriegers Flak Combined Grid Solution – Four Technical Layers

Layer 1: Dots and lines – Main idea

What and where to build?

## Kriegers Flak Combined Grid Solution – Four Technical Layers

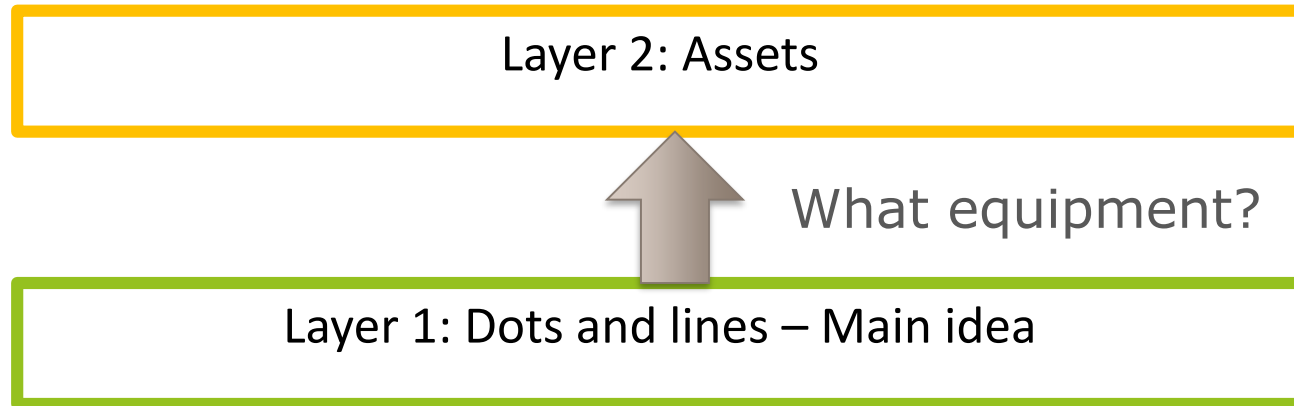

## Kriegers Flak Combined Grid Solution – Four Technical Layers

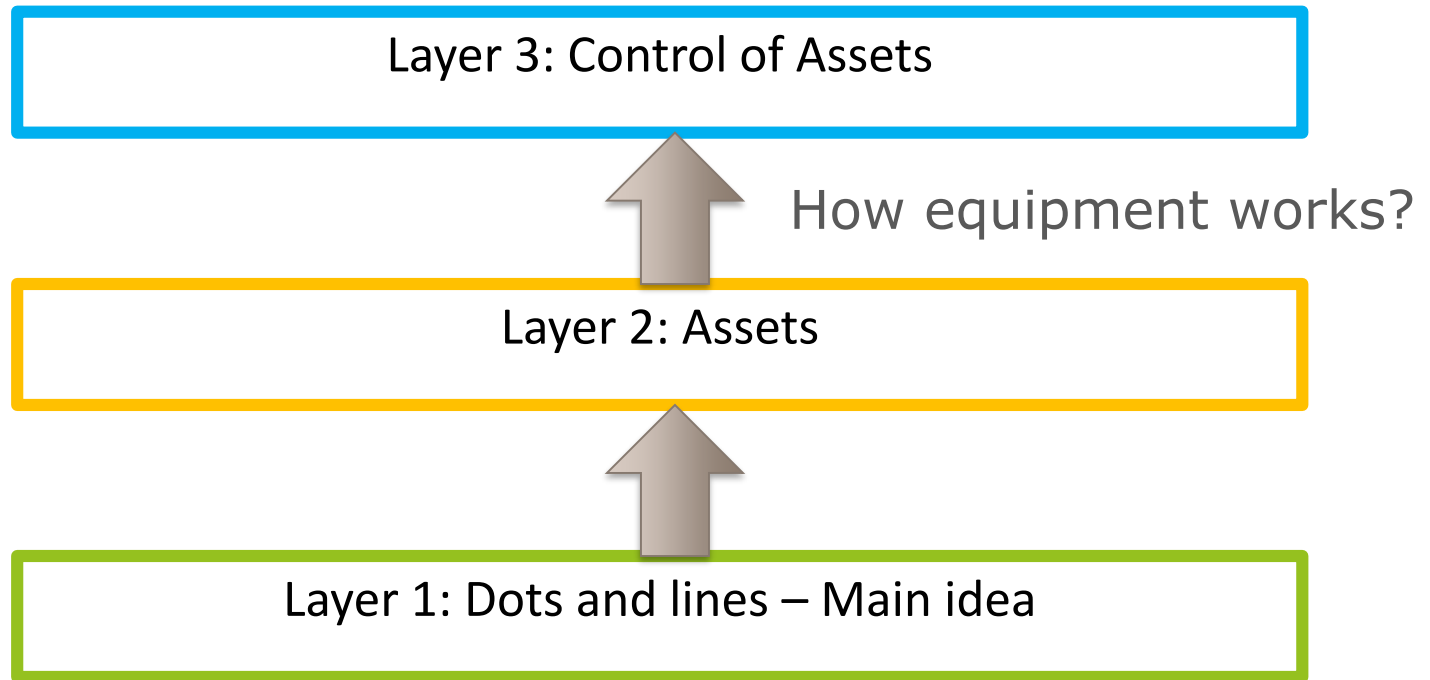

## Kriegers Flak Combined Grid Solution – Four Technical Layers

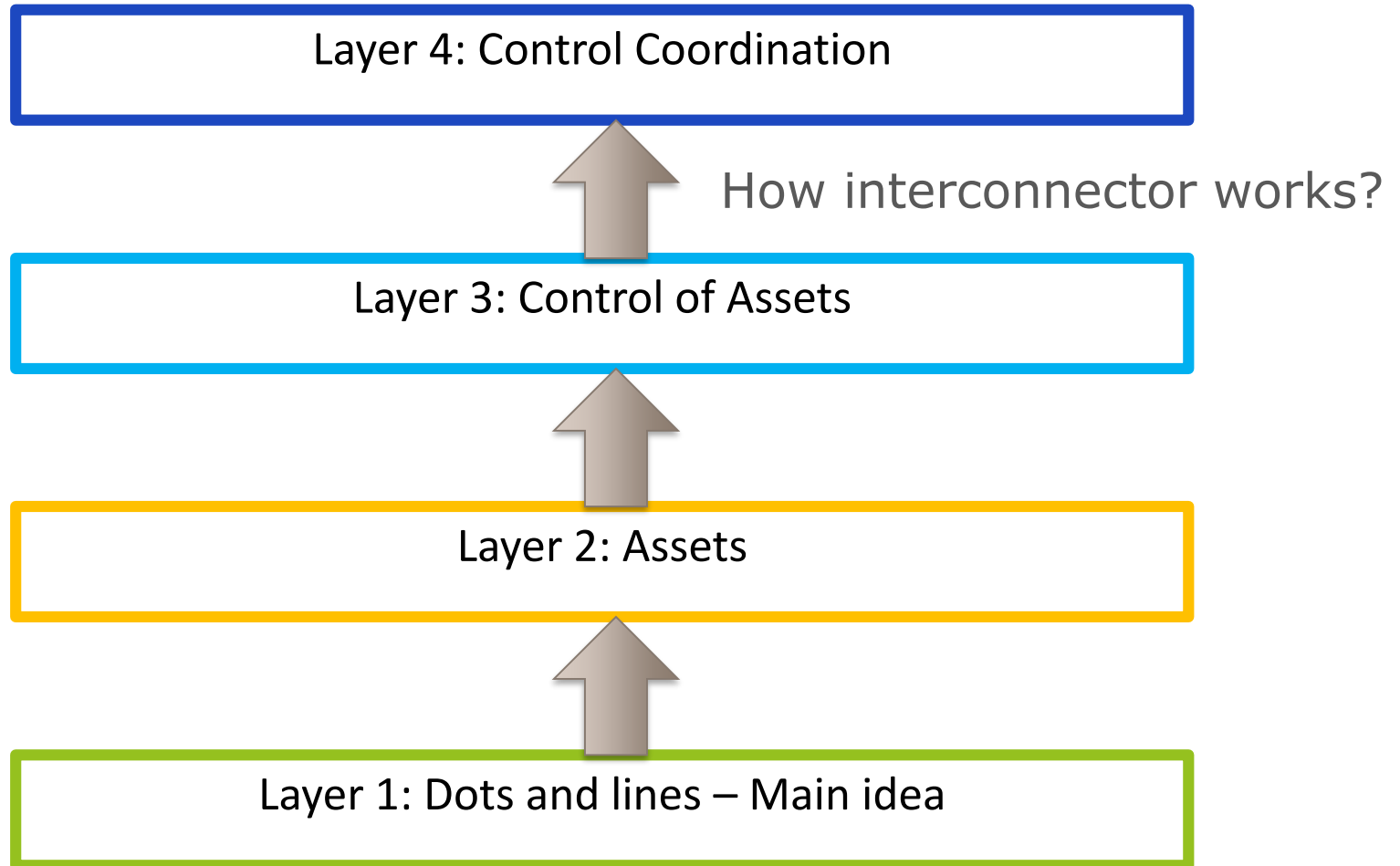

## Kriegers Flak Combined Grid Solution – Four Technical Layers

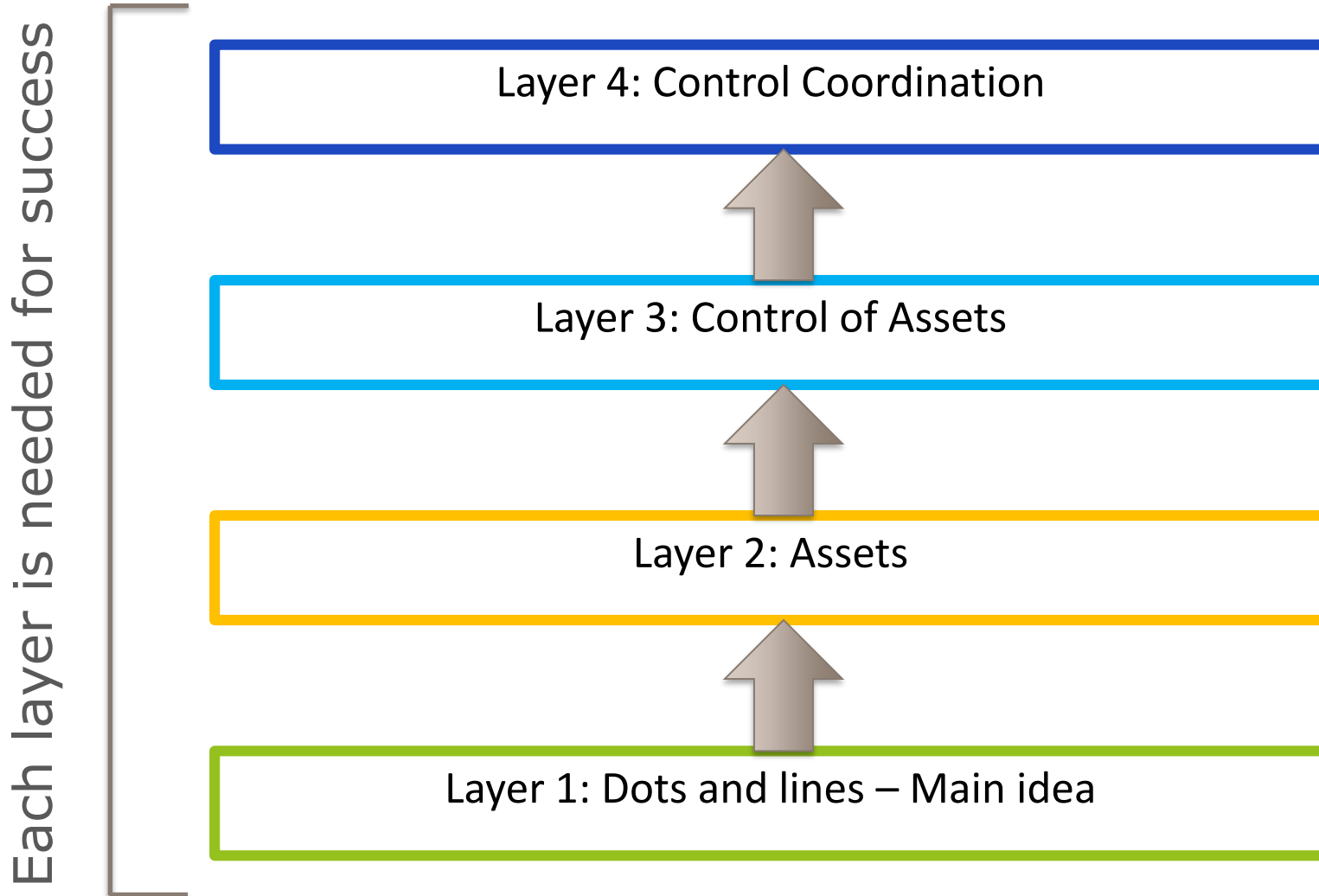

## Energy transport



1. Business As Usual.
2. Offshore wind to Land  
(High wind scenarios)



## Energy transport



1. Interconnector.
2. Offshore wind to Land  
(High wind scenarios)

## Energy transport



1. Interconnector.
  2. Offshore wind to Land
- (High wind scenarios)

## Energy transport



1. Land to Offshore.
  2. Then Offshore to Land
- (Low/No wind scenarios)

## Energy transport



1. Land to Offshore.
  2. Then Offshore to Land
- (Low/No wind scenarios)

## **Lessons learned from this presentation**

1. Kriegers Flak CGS utilizes existing and added offshore and onshore assets.
2. Grid-connection of Offshore Wind and an Interconnector between Denmark and Germany.
3. Meshed offshore HVAC grid combined with HVDC Back-to-Back in Germany (Bentwisch).
4. Technical - "The Four Layers" combining the idea, assets and advanced control.
5. Energy transports – Business as usual from Platforms to Land.
6. Energy transport – From Land into Platforms and then to Land.

## Acknowledgements

The Kriegers Flak Combined Grid Solution is granted with financial support from the European Energy Programme for Recovery (EEPR) of the European Union.

However, for the avoidance of doubt, the European Commission is not responsible for any use that may be made of the information contained in this paper.

## **SPARE SLIDE: Energy and power transmission**

1. KFE platform is the point-of-settlement.
2. Wind power forecasts, availability of equipment, Dynamic Line Rating (DLR), onshore grid limitations.
3. Optimal Power Flow (by the MIO).
4. Capacity calculations by 5 min. to the market.
5. Market schedule received by the MIO.
6. The MIO secures the market schedule (adjusting BtB):
  - Available transfer capacity utilized by wind power and market to a maximum of 100%.
  - Higher grid access priority of wind power than for market schedule (in case of congestions: market will be curtailed first).
  - The wind power from Baltic 1 and Baltic 2 must be transmitted to Germany and the wind power from KFA and KFB to Denmark, respectively.
7. In case of forecast errors or equipment overloading:
  - Curtail the market schedule, if necessary to 0 MW.
  - If not resolved, curtail the wind power of the relevant section.
  - Curtail less possible.



## **SPARE SLIDE: Lessons learned from this presentation**

1. Kriegers Flak CGS utilizes existing and added offshore and onshore assets.
2. Grid-connection of offshore wind power and an interconnector between Denmark and Germany.
3. Most possible assets are onshore.
4. HVDC Back-to-Back in Bentwisch (Germany).
5. Meshed offshore HVAC grid.
6. Energy and power transport from offshore platforms to the onshore grids (usual way), and in the opposite direction.
7. Optimal Power Flow.
8. Dynamic Line Rating (DLR) applies.
9. Automatic voltage and reactive power control (AVR/RPC).
10. Advanced control of wind power plants, BtB, other equipment.
11. Master Controller for Interconnector Operation – the must for coordination.
12. Several other control systems apply (not included in this presentation).